

# Puppy Pounce

By Perry Bailey ©1997

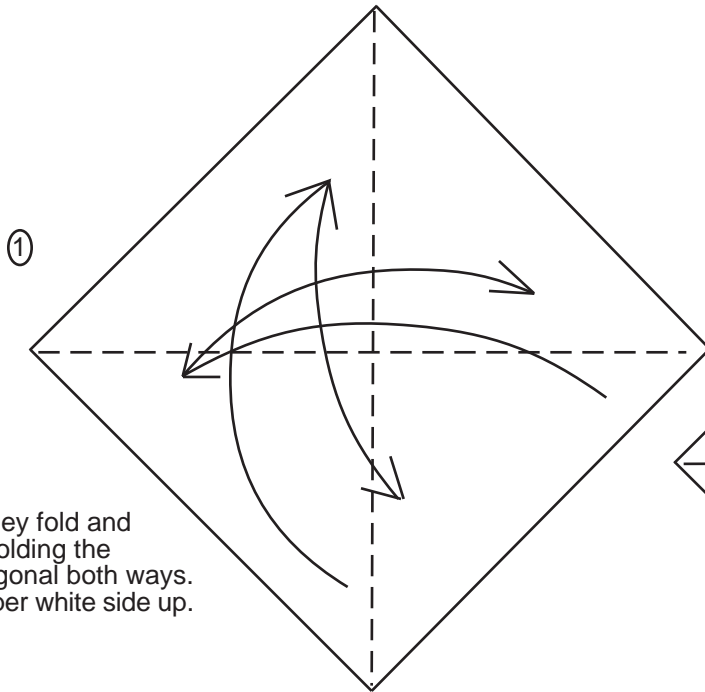

Valley fold and unfolding the diagonal both ways. Paper white side up.

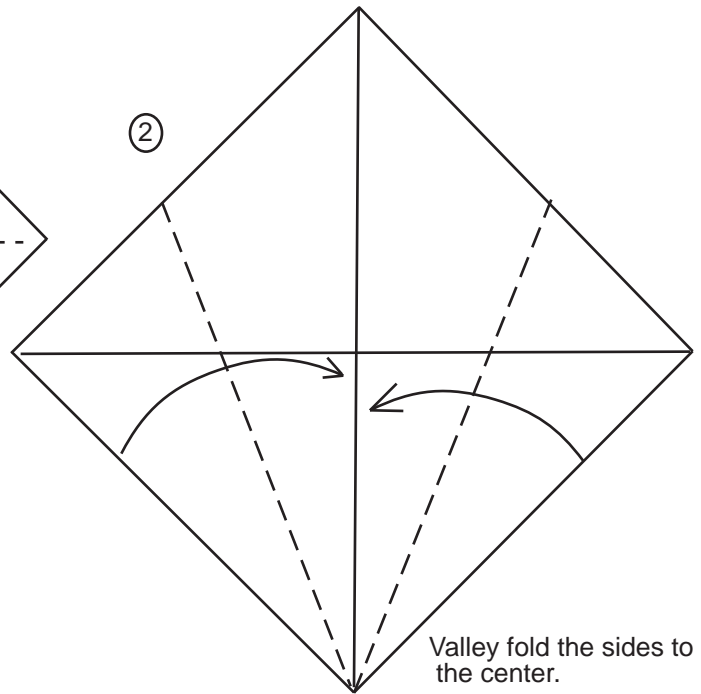

Valley fold the sides to the center.

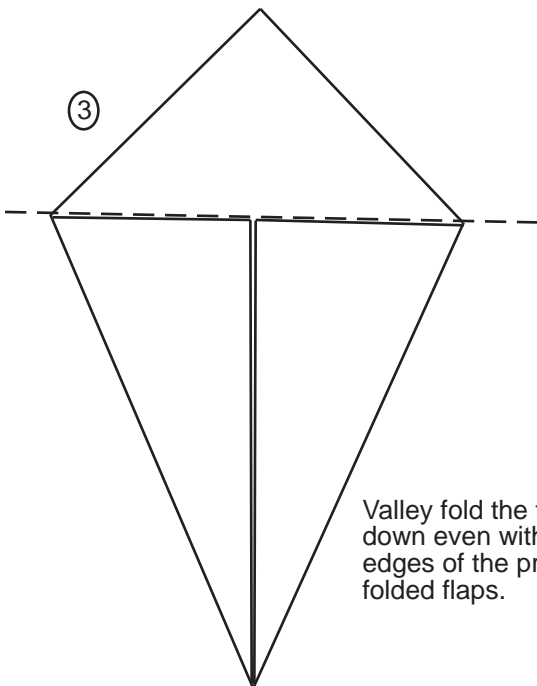

Valley fold the top flap down even with the raw edges of the previously folded flaps.

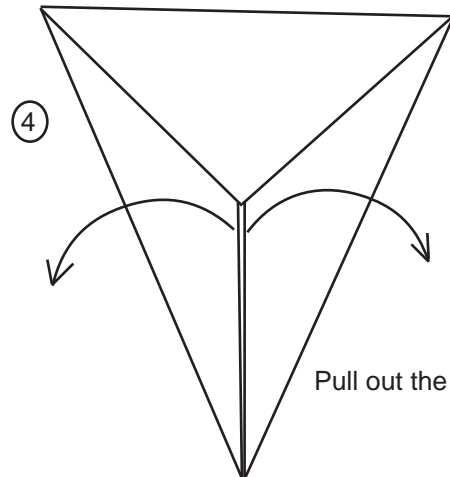

Pull out the two side flaps.

5

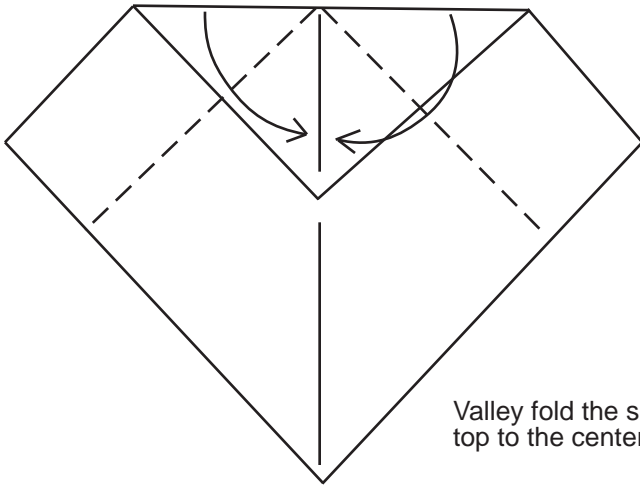

Valley fold the sides from the top to the center of the model.

6

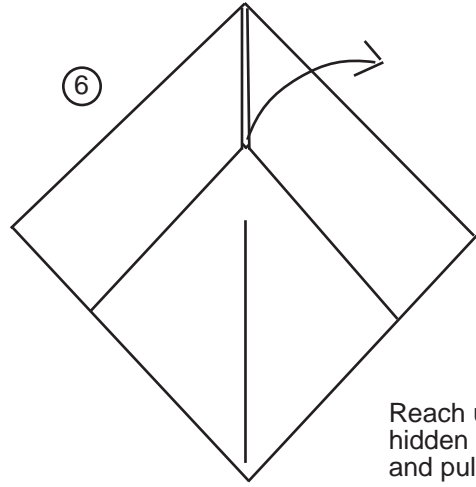

Reach under to the hidden center flap and pull it out.

7

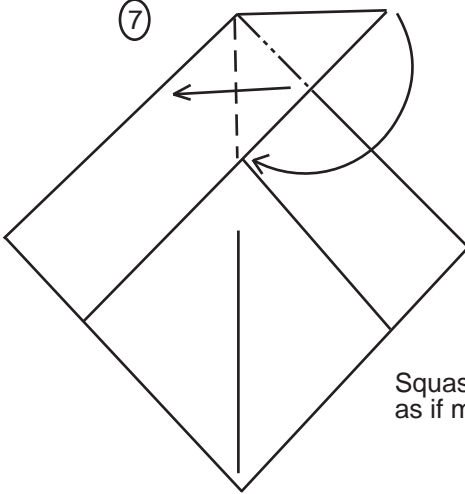

Squash fold the flap down as if making a preliminary base.

8

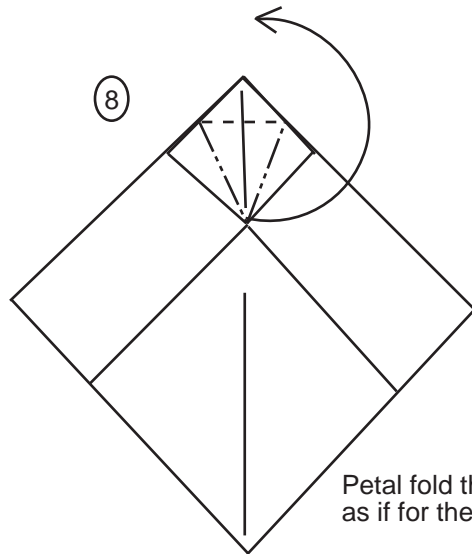

Petal fold the top flap up as if for the bird base.

9

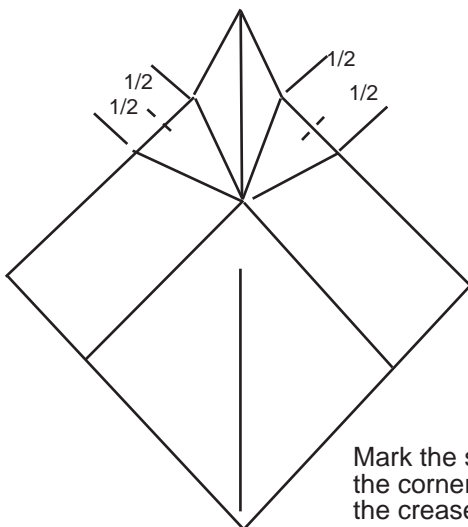

Mark the spot half way between the corner of the bird base and the crease formed in step 2.

10

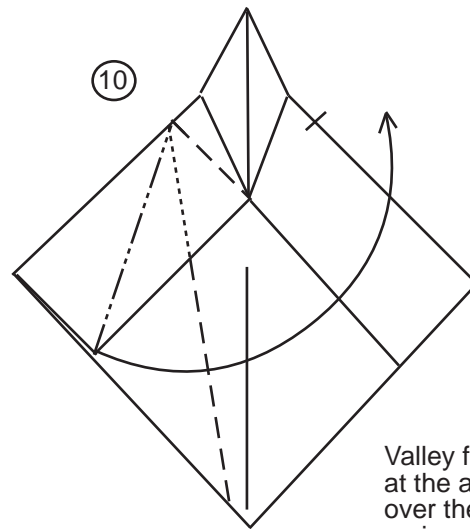

Valley fold the top layer only at the angle bisector, then fold over the flap as shown to form an irregular rabbits ear. Note, the long line on the bottom layer does not go to the tip. It is formed by flattening the paper after the two folds on the top layer.

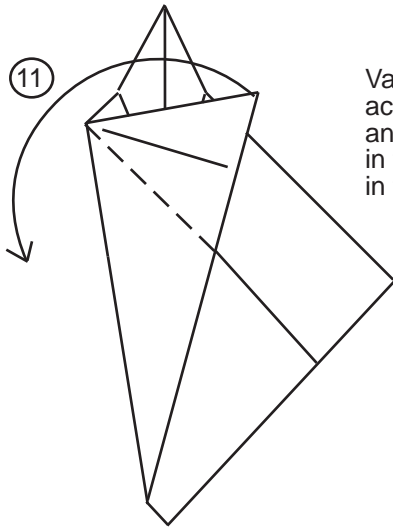

Valley fold the flap back across it's self, so that the angle bisector you folded in the last step is unfolded in this step.

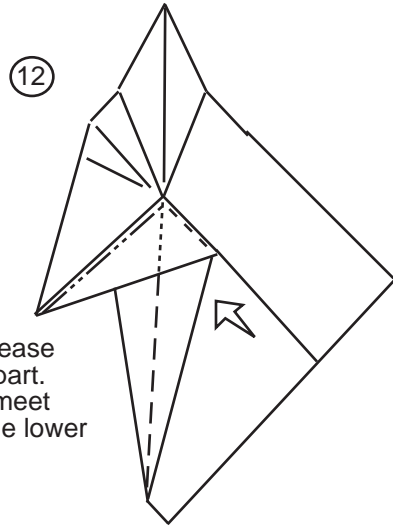

Swivel fold the flap under itself so the raw edge and the crease meet, on the upper part. The crease will not meet the edge all along the lower part.

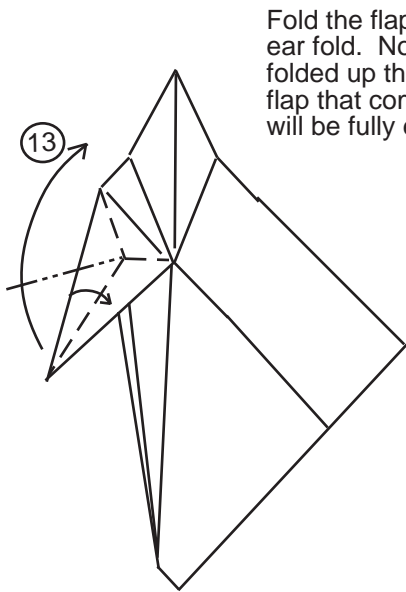

Fold the flap up in a rabbits ear fold. Note that when folded up the paper under the flap that comes to the surface will be fully extended.

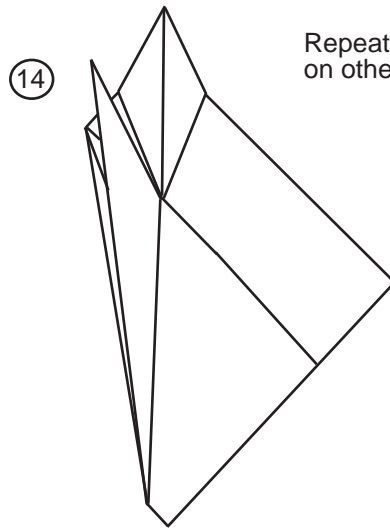

Repeat steps 10 - 13 on other side.

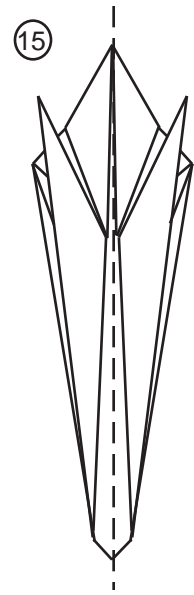

Valley fold in half and turn 90 degrees to the left.

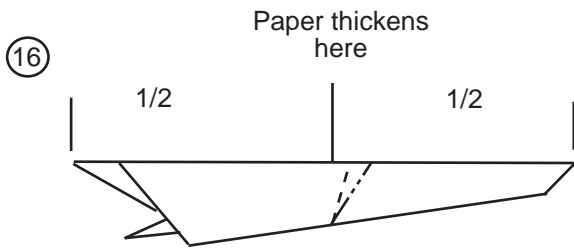

Paper thickens here

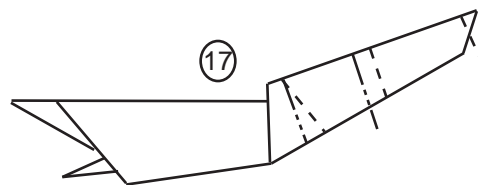

Crimp fold the front of the model back so that the bottom of the crimp is even with where the paper thickens at the top, and so that it will stick up above the surface at the top

Now we form the head, all it takes in order left to right, a crimp, a pleat an outside reverse fold.

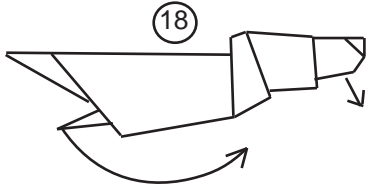

Valley fold the legs forward, as seen in 19  
Pull the snout down a little to taste.

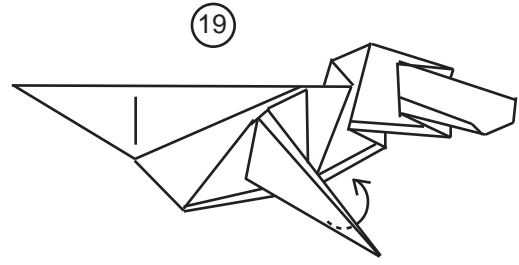

This is a cut away view of the inside of the model, as if the entire front half were missing. At this point work a colour change on the front legs by taking the bottom layer of the front leg and pull it out.

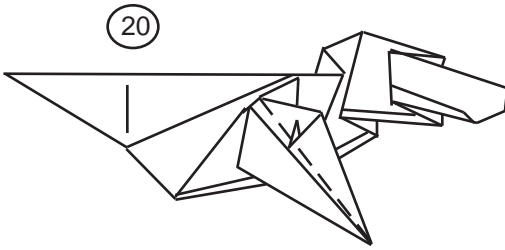

Then tuck the layer you pulled out in the previous step and tuck it into the leg, this will make the leg the same colour as the body.

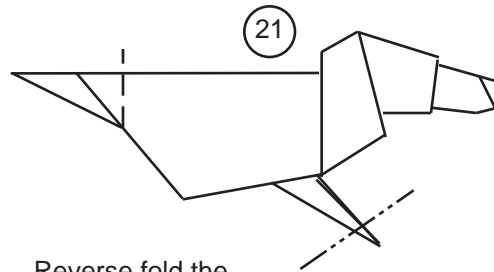

Reverse fold the tips of the front legs in to themselves. Then reverse fold the top two layers of the rear end over towards the front.

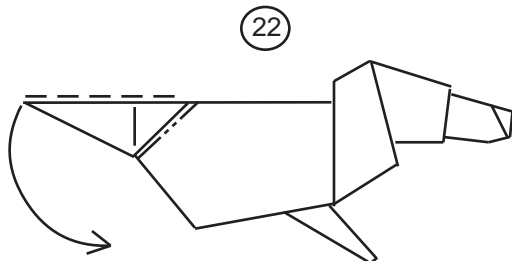

Reverse fold the hind end down.

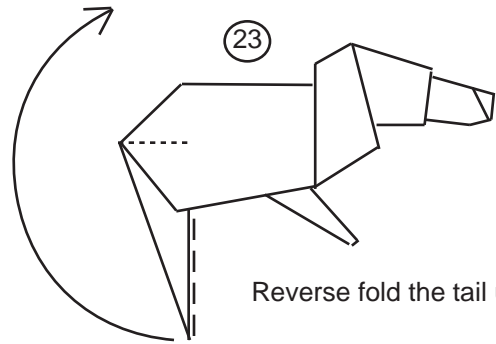

Reverse fold the tail up.

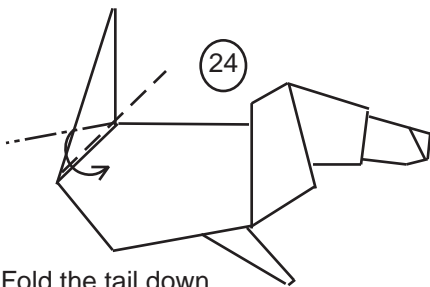

Fold the tail down with a crimp fold, then tuck the outside flaps in to the model.

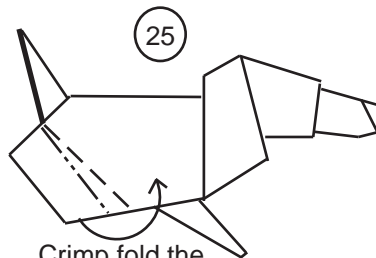

Crimp fold the body to form the rear end of the dog. (Here is a hint, do it one side at a time.)

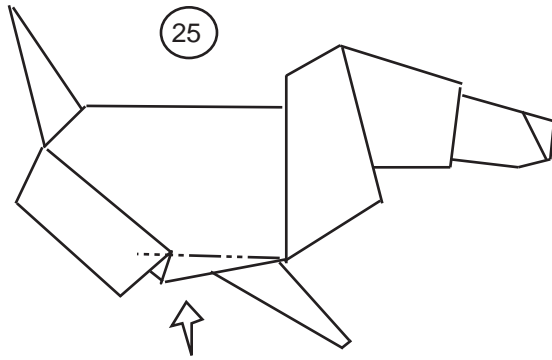

Mountain fold the excess paper up inside of the model and your done!

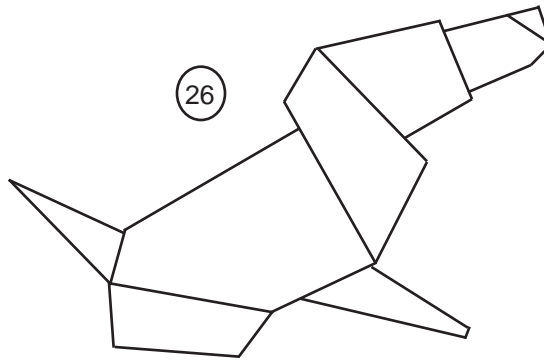

To See the puppy pounce, just tap his tail!